



01/2007 - 09/2012

## HONDA CRV

Cat. No. **H/015**

e20

e20\*94/20\*1001\*00

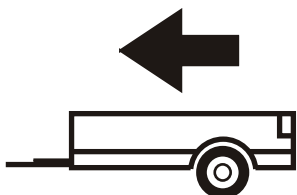

2000kg

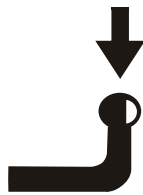

100kg

**D**=10,43kN

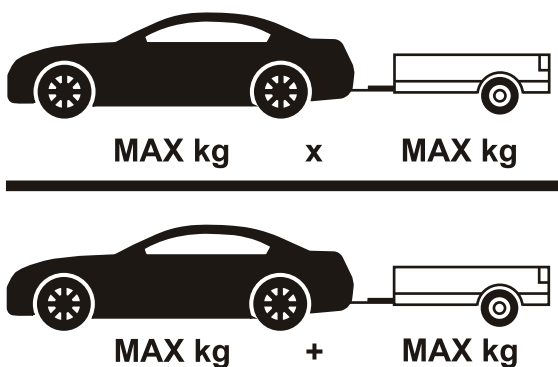
$$D \text{ (kN)} = \frac{\text{MAX kg} \times \text{MAX kg}}{\text{MAX kg} + \text{MAX kg}} \times 0,00981$$

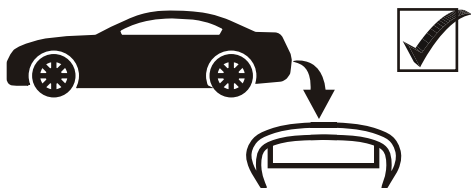

IMIOLA HAK-POL

96-111 KOWIESY, CHOJNATA 23A, POLAND

Tel. + 48 46 831 73 31, fax +48 831 74 29

e-mail: [office@imiola.pl](mailto:office@imiola.pl), [www.imiola.pl](http://www.imiola.pl)

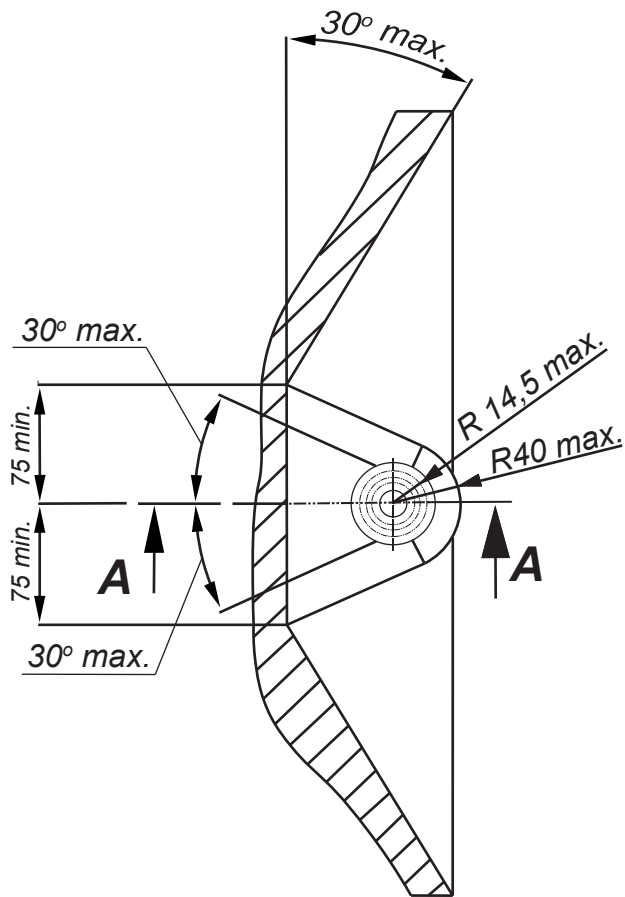

## PRZEKRÓJ A-A

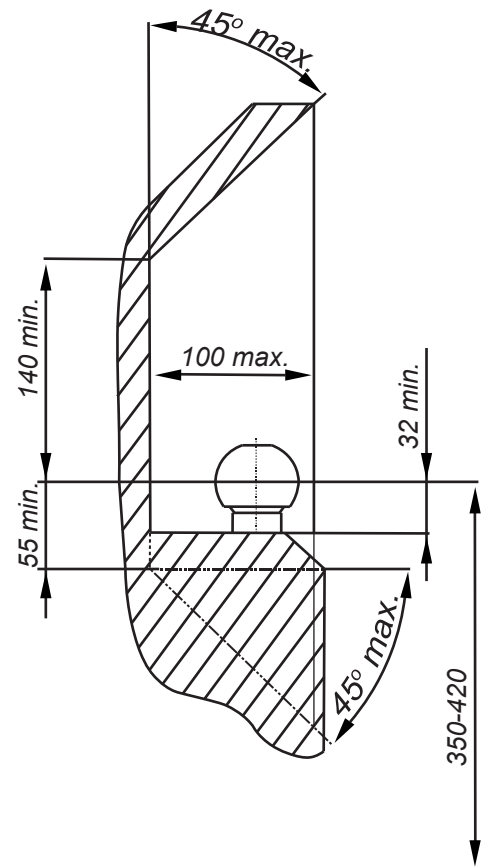

**PL** Należy zagwarantować przestrzeń swobodną według załącznika VII, rysunek 25a/b Regulaminu EKG ONZ 55.01 przy dopuszczalnym ciężarze całkowitym pojazdu.

**F** L'espace libre doit être garanti conformément à l'annexe VII, illustration de la réglementation 55.01 CE pour un poids total en charge autorisé du véhicule.







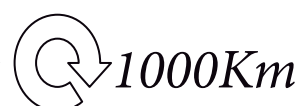

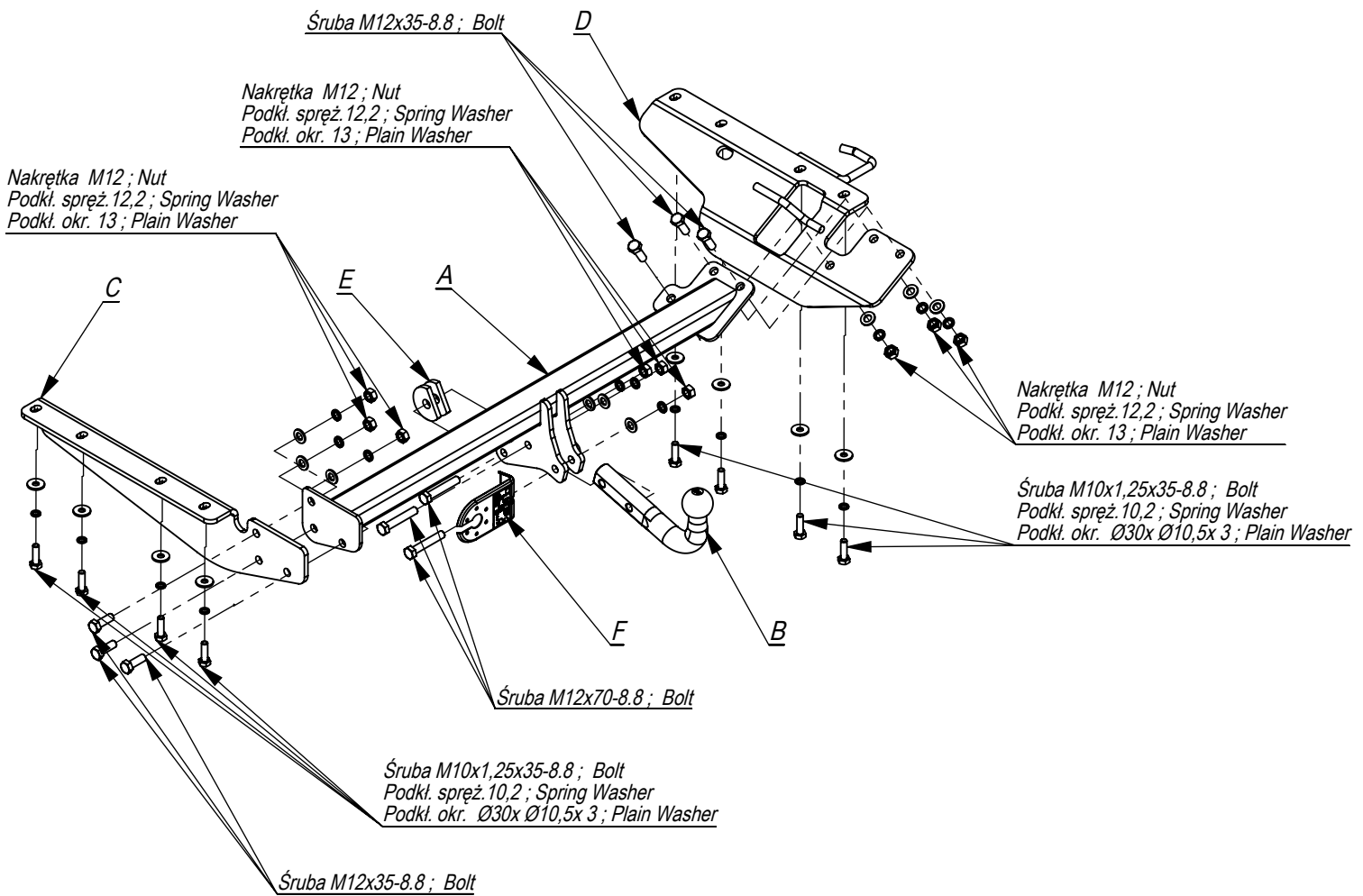

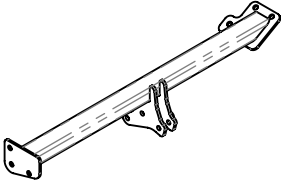
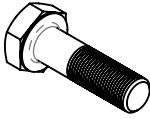

**GB** The clearance specified in appendix VII, diagram 25a/b of Regulation No. 55.01 UN EU must be guaranteed at laden weight of the vehicle.

**D** Der Freiraum nach Anhang VII, Abbildung 25a/b der Vorschriften 55.01 EG ist zu gewährleisten bei zulässigem Gesamtgewicht des Fahrzeuges.

Moment skracający dla śrub i nakrętek (8.8) Torque settings for nuts and bolts (8.8)	
M8	25Nm
M10	55Nm
M12	85Nm
M14	135Nm
M16	195Nm





	A	x1		M12x70	3
				M12x35	6
				M10x1,25x35	8
	B	x1		M12	9
					Ø30xØ10,5x3
	C	x1		13	9
					12,2
	D	x1		10,2	8
					10,2
	E	x2			
	F	x1			

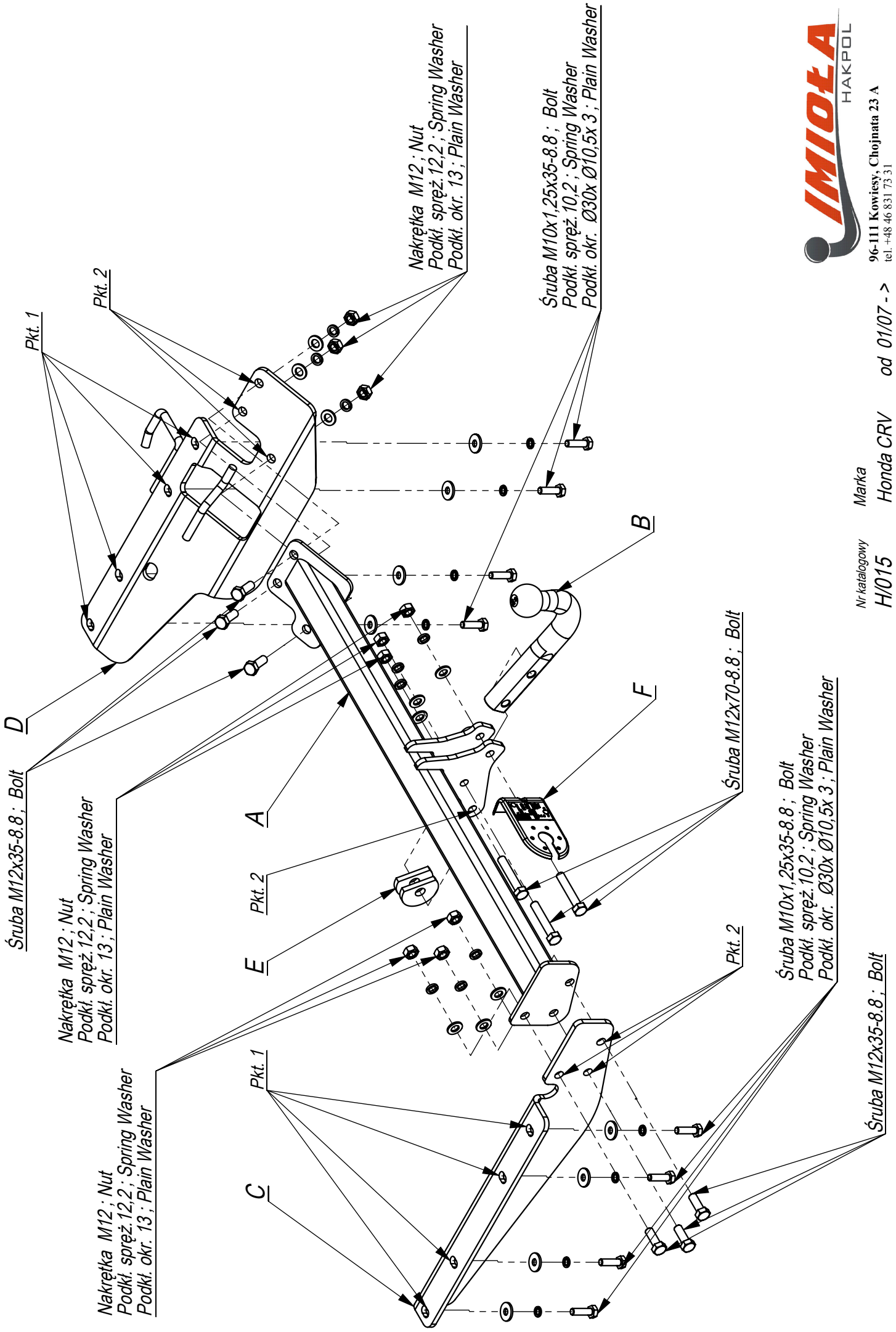

- Zdemontować zderzak.
- Opuścić tłumik z tylnych zawiesi.
- Gumowe zawiesia tłumika umocować na elemencie D.
- Element D przykręcić lekko do prawej podłużnicy śrubami M10x1,25x40 8.8 (pkt 1) stosując podkładki.
- Element C przykręcić lekko do lewej podłużnicy śrubami M10x1,25x40 8.8 (pkt 1) stosując podkładki.
- Belkę haka A przykręcić do elementów C i D śrubami M12x35 8.8 (pkt 2) oraz śrubą M12x70 8.8 do ucha holowniczego stosując podkładki E.
- Dokręcić wszystkie śruby z momentem wg tabeli.
- Wykonać wycięcie w zderzaku 50x10 w jego dolnej części.
- Przykręcić zderzak.
- Przykręcić kulę i blachę gniazda elektrycznego.
- Podłączyć instalację elektryczną.

- Disassemble the bumper.
- Lower the damper from rear hangers.
- Assemble the rubber hangers of the damper on the element D.
- Screw slightly the element D to the right metal clamp with bolts M10x1,25x40 8.8 (point 1) using washers.
- Screw slightly the element C to the left metal clamp with bolts M10x1,25x40 8.8 (point 1) using washers.
- Screw the main bar A to the elements C and D with bolts M12x35 8.8 (point 2) and to the towing eye with bolt M12x70 8.8 using washers E.
- Tighten all the bolts according to the torque setting- see the table.
- Cut out the fragment 50x10 in the lower part of the bumper.
- Assemble the bumper.
- Fix the ball and electric plate.
- Connect the electric wires.

- Déposer le pare-chocs.
- Descendre le silencieux des pattes arrière.
- Les pattes de silencieux en caoutchouc sur l'élément D.
- Serrer légèrement l'élément D au longeron droit avec les boulons M10x1,25x35 8.8 (point 1) en utilisant les rondelles.
- Serrer légèrement l'élément C au longeron gauche avec les boulons M10x1,25x35 8.8 (point 1) en utilisant les rondelles.
- Serrer la traverse de crochet A aux éléments C et D avec les boulons M12x35 8.8 (point 2) et boulon M12x70 8.8 à l'oreille d'attelage en utilisant les rondelles E.
- Serrer tous les boulons avec un couple de serrage selon tableau.
- Entreouvrir le pare-chocs en partie basse de 50x10.
- Fixer un pare-chocs.
- Visser la boule et tôle de la prise électrique.
- Raccorder le circuit électrique.

- Die Stoßstange demontieren.
- Den Ausputopf aus den hinteren Aufhängungen absenken.
- Die Gummiaufhängungen des Ausputopfs auf dem Tragteil D befestigen.
- Das Tragteil D an den rechten Längsträger mit den Schrauben M10x1,25x40 (Punkt 1), mit den Unterlegscheiben locker anschrauben.
- Das Tragteil C an den linken Längsträger mit den Schrauben M10x1,25x40 8.8 (Punkt 1) mit den Unterlegscheiben locker anschrauben.
- Den Querbalken A an die Tragteile C und D mit den Schrauben M12x35 8.8 (Punkt 2) und der Schraube M12x70 8.8 an die Abschleppöse mit den Unterlegscheiben E anschrauben.
- Alle Schrauben mit dem in der Tabelle angegebenen Drehmoment festziehen.
- Einen Ausschnitt in der Stoßstange 50x10, in ihrem unteren Teil ausführen.
- Die Stoßstange anschrauben.
- Die Kugel mit den Schrauben anschrauben.
- Die Elektroinstallation anschließen.

- Desmontar el parachoques.
- Baje el silenciador de las eslingas traseras.
- Coloque las eslingas de goma del silenciador en el elemento D.
- Fijar el elemento D ligeramente al miembro longitudinal izquierdo con tornillos M10x1, 25x40, 8.8 (punto 1) usando arandelas.
- Fijar el elemento C ligeramente al miembro longitudinal izquierdo con tornillos M10x1, 25x40, 8.8 (punto 1) usando arandelas.
- Apretar suavemente la barra del gancho A a los elementos C y D con tornillos M12x35 8.8 (punto 2) y pernos M12x70 8.8 al orificio de remolque usando arandelas E.
- Apretar todos los tornillos con el par según la tabla anterior.
- Haga el recorte en la parte inferior del parachoques con dimensiones 50x10.
- Apretar el parachoques.
- Apretar la bola y la placa de la toma eléctrica.
- Conectar la instalación eléctrica.

